

# Home Standby – 16kW

## Air-Cooled Gas Engine Generator Sets

**QUIET TEST™**

Low Speed Exercise  
61 dB(A) at 23 feet

Continuous Standby Power Rating – 16kW 60 Hz

Models: #05254

#05255

### INCLUDES:

- Electronic Governor
- Flexible Fuel Line
- Composite Mounting Pad
- Natural Gas or LP Gas Operation
- UL 2200 Listed



## FEATURES

- **INNOVATIVE DESIGN & PROTOTYPE TESTING** are key components of GENERAC'S success in "IMPROVING POWER BY DESIGN." But it doesn't stop there. Total commitment to component testing, reliability testing, environmental testing, destruction and life testing, plus testing to applicable CSA, NEMA, EGSA, and other standards, allows you to choose GENERAC POWER SYSTEMS with the confidence that these systems will provide superior performance.
- **TEST CRITERIA:**
  - ✓ PROTOTYPE TESTED
  - ✓ SYSTEM TORSIONAL TESTED
  - ✓ NEMA MG1-22 EVALUATION
  - ✓ MOTOR STARTING ABILITY
- **SOLID-STATE, FREQUENCY COMPENSATED VOLTAGE REGULATION.** This state-of-the-art power maximizing regulation system is standard on all Generac models. It provides optimized FAST RESPONSE to changing load conditions and MAXIMUM MOTOR STARTING CAPABILITY by electronically torque-matching the surge loads to the engine.
- **SINGLE SOURCE SERVICE RESPONSE** from Generac's dealer network provides parts and service know-how for the entire unit, from the engine to the smallest electronic component. You are never on your own when you own a GENERAC POWER SYSTEM.
- **GENERAC TRANSFER SWITCHES.** Long life and reliability are synonymous with GENERAC POWER SYSTEMS. One reason for this confidence is that the GENERAC product line includes its own transfer systems and controls for total system compatibility.

**GENERAC®**  
POWER SYSTEMS, INC.

# HOME STANDBY SPECIFICATIONS

Home Standby – 16kW

<b>ENGINE</b>	<ul style="list-style-type: none"> <li>• Generac (OHVI) Design</li> <li>• "Spiny-lok" cast iron cylinder walls</li> <li>• Electronic ignition, spark advance and compression release</li> <li>• Full pressure lubrication system</li> <li>• Low oil pressure shutdown system</li> <li>• High temperature shutdown</li> </ul>	<p>Maximizes engine "breathing" for increased fuel efficiency. Cylinder walls run cooler, reducing oil consumption. Because heat is the primary cause of engine wear, the OHVI has a significantly longer life than competitive engines.</p> <p>Rigid construction and added durability provide long engine life.</p> <p>These features combine to assure smooth, quick starting every time.</p> <p>Superior lubrication to all vital bearings means better performance, less maintenance and significantly longer engine life.</p> <p>Superior shutdown protection prevents catastrophic engine damage due to low oil.</p> <p>Prevents damage due to overheating.</p>
<b>GENERATOR</b>	<ul style="list-style-type: none"> <li>• Revolving field</li> <li>• Skewed stator</li> <li>• Displaced phase excitation</li> <li>• Automatic voltage regulation</li> <li>• UL 2200 Listed</li> </ul>	<p>Allows for smaller, light weight unit that operates 25% more efficiently than a revolving armature generator.</p> <p>Produces a smooth output waveform for compatibility with electronic equipment.</p> <p>Maximizes motor starting capability. Provides more surge capability than brushless generator designs.</p> <p>Regulates the output voltage to <math>\pm 2\%</math> prevents damaging voltage spikes.</p> <p>For your safety.</p>
<b>TRANSFER SWITCH (OPT)</b>	<ul style="list-style-type: none"> <li>• Fully Automatic</li> <li>• 100, 200 or 400 Amp (options)</li> <li>• Remote Mounting</li> <li>• UL Listed</li> </ul>	<p>Transfers your vital electrical loads to the energized source of power.</p> <p>Required (order separately).</p> <p>Mounts near your existing distribution panel for simple, low cost installation.</p> <p>For your safety.</p>
<b>MICROPROCESSOR CONTROL</b>	<ul style="list-style-type: none"> <li>• Manual/Auto/Off switch</li> <li>• Utility voltage sensing</li> <li>• Utility interrupt delay</li> <li>• Engine warm-up</li> <li>• Engine cool-down</li> <li>• Seven day exerciser</li> <li>• Timed Trickle Battery charger</li> <li>• Main Line Circuit Breaker</li> </ul>	<p>Selects the operating mode.</p> <p>Constantly monitors utility voltage, setpoints 60% dropout, 80% pick-up, of standard voltage.</p> <p>Prevents nuisance start-ups of the engine, set point approximately 10 seconds.</p> <p>Ensures engine is ready to assume the load, setpoint approximately 10 seconds.</p> <p>Allows engine to cool prior to shutdown, setpoint approximately 1 minute.</p> <p>Operates engine to prevent oil seal drying and damage between power outages.</p> <p>Maintains battery voltage to insure starting.</p> <p>Protects generator from overload.</p>
<b>UNIT</b>	<ul style="list-style-type: none"> <li>• Weather protective enclosure</li> <li>• Enclosed critical grade muffler</li> <li>• Small, compact, attractive</li> </ul>	<p>Ensures protection against mother nature. Hinged key locking roof panel for security. Lift-out front for easy access to all routine maintenance items. Electrostatically applied textured epoxy paint for added durability.</p> <p>Quiet, critical grade muffler is mounted inside the unit to prevent injuries.</p> <p>Makes for an easy, eye appealing installation.</p>
<b>INSTALLATION KIT</b>	<ul style="list-style-type: none"> <li>• 1' Flexible Fuel Line</li> <li>• Composite Mounting Pad (Std)</li> </ul>	<p>Easy Installation.</p>

## Home Standby – 16kW

GENERATOR	Model 05254 - Steel, Model 05255 - Aluminum
Rated Maximum Continuous Power Capacity (LP) .....	16,000 Watts*
Rated Maximum Continuous Power Capacity (NG) .....	15,000 Watts*
Rated Voltage .....	120/240
Rated Maximum Continuous Load Current	
240 Volts .....	66.6 LP/62.5 NG
Main Line Circuit Breaker .....	65 Amp
Phase .....	1
Number of Rotor Poles .....	2
Rated AC Frequency .....	60Hz
Power Factor .....	1
Battery Requirement (not included) .....	Group 26, 12 Volt Negative Ground and 525 Cold-cranking Amperes Minimum
Unit Weight .....	445 Pounds
Dimensions (L" x W" x H") .....	48 x 24 x 28-1/4
Sound output in dB(A) at 23 ft. with generator operating at full load .....	72
Sound output in dB(A) at 23 ft. with generator in Quiet-Test™ exercise mode .....	61
ENGINE	Model 05254 - Steel, Model 05255 - Aluminum
Type of Engine .....	GENERAC OHVI V-TWIN
Number of Cylinders .....	2
Rated Horsepower .....	30 @ 3,600 rpm
Displacement .....	992cc
Cylinder Block .....	Aluminum w/Cast Iron Sleeve
Valve Arrangement .....	Overhead Valve
Ignition System .....	Solid-state w/Magneto
Governor System .....	Electronic
Compression Ratio .....	9.5:1
Starter .....	12Vdc
Oil Capacity Including Filter .....	Approx. 1.7 Qts.
Standby Operating RPM .....	3,600
Exercise RPM .....	2,400
Fuel Consumption	
Natural Gas   cu.ft./hr.	
1/2 Load .....	173
Full Load .....	250
Liquid Propane   ft <sup>3</sup> /hr (gal/hr)	
1/2 Load .....	59 (1.59)
Full Load .....	100 (2.77)
Required fuel pressure to generator fuel inlet at all load ranges - 5 to 7 inches of water column for natural gas, 10 to 12 inches of water column for LP gas	
CONTROLS	
Mode Switch	
- Auto	- Automatic start and stop on utility failure and return. 7 day exerciser. Cyclic cranking 7 seconds on, 7 seconds rest for 90 seconds maximum.
- Off	- Stops unit. Power is removed from controller. Battery charger will still operate.
- Manual/Test (start)	- Start with starter control, unit will stay on. If utility fails, transfer will take place.

## HOME STANDBY TRANSFER SWITCH (ORDERED SEPARATELY)

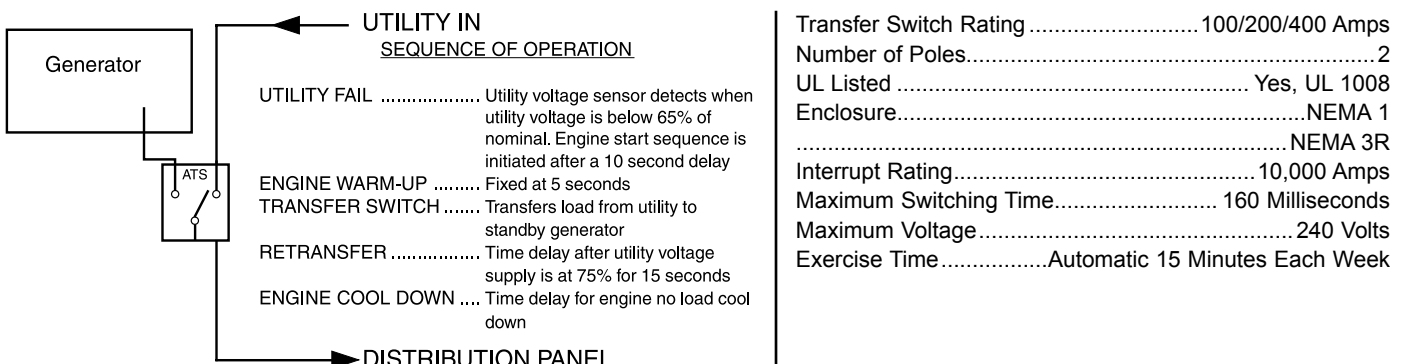

Rating definitions - Standby: Applicable for supplying emergency power for the duration of the utility power outage. No overload capability is available for this rating. (All ratings in accordance with BS5514, ISO3046 and DIN6271). Prime (Unlimited Running Time): Unit not recommended for prime power applications. Applicable for supplying electric power in lieu of commercially purchased power. Prime power is the maximum power available at variable load. A 10% overload capacity is available for 1 hour in 12 hours. (All ratings in accordance with BS5514, ISO3046, ISO8528 and DIN6271). \* Maximum wattage and current are subject to and limited by such factors as fuel Btu content, ambient temperature, altitude, engine power and condition, etc. Maximum power decreases about 3.5 percent for each 1,000 feet above sea level; and also will decrease about 1 percent for each 12° C (10° F) above 15.5° C (60°F).

# STANDARD ENGINE & SAFETY FEATURES

Home Standby – 16kW

- High Temperature Automatic Shutdown
- Low Oil Pressure Automatic Shutdown
- Overspeed Automatic Shutdown (Solid-state)
- Crank Limiter (Solid-state)
- Oil Drain Extension
- Rubber-Booted Engine Electrical Connections
- Fuel Lockoff Solenoid
- Secondary Fuel Regulator (N.G. and L.P.)
- Battery Charge Alternator
- Battery Cables
- Battery Tray
- Vibration Isolation of Unit to Mounting Base
- 12 Volt, Solenoid-Activated Starter Motor
- Air Cleaner
- Fan Guard
- Control Console
- Muffler Guard
- Flexible Fuel Lines
- Critical Exhaust Silencer
- Battery Trickle Charger
- Main Line Circuit Breaker
- Weather Protective Enclosure (Locking Type)

## HOME STANDBY CONTROL FEATURES

### Home Standby Control Console

- Manual/Auto/Off switch
- Fault indicator lamp
- Fuse (panel overload)
- Set exercise time switch

### Home Standby Microprocessor Controls

- Automatic voltage regulation
- Utility voltage sensing
- Utility interrupt delay (10-second setpoint)
- Engine warm-up (10-second setpoint)
- Engine cool-down (1-minute setpoint)
- Seven-day exerciser

Design and specifications subject to change without notice. Dimensions shown are approximate. Contact your Generac dealer for certified drawings. DO NOT USE THESE DIMENSIONS FOR INSTALLATION PURPOSES.

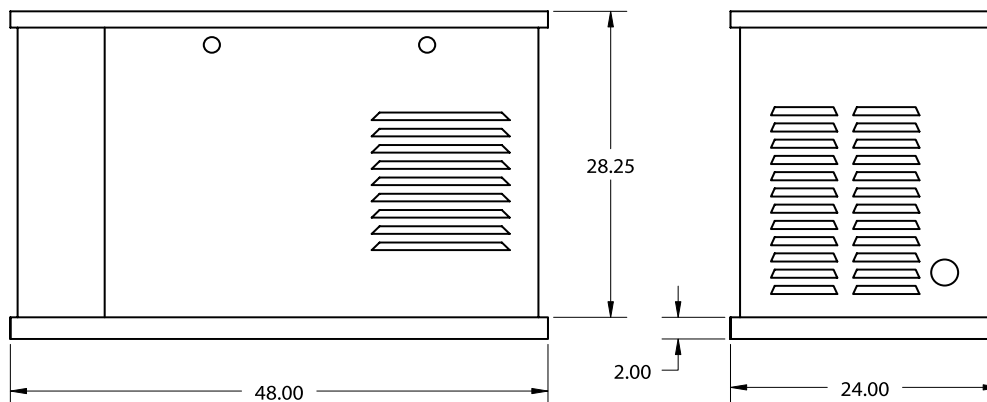

16 kW UNIT WEIGHT: 445 lbs.

**GENERAC** POWER SYSTEMS, INC. • P.O. BOX 8 • WAUKESHA, WI 53187  
262/544-4811 • FAX 262/544-4851